

2 - 24" (50 - 610mm)

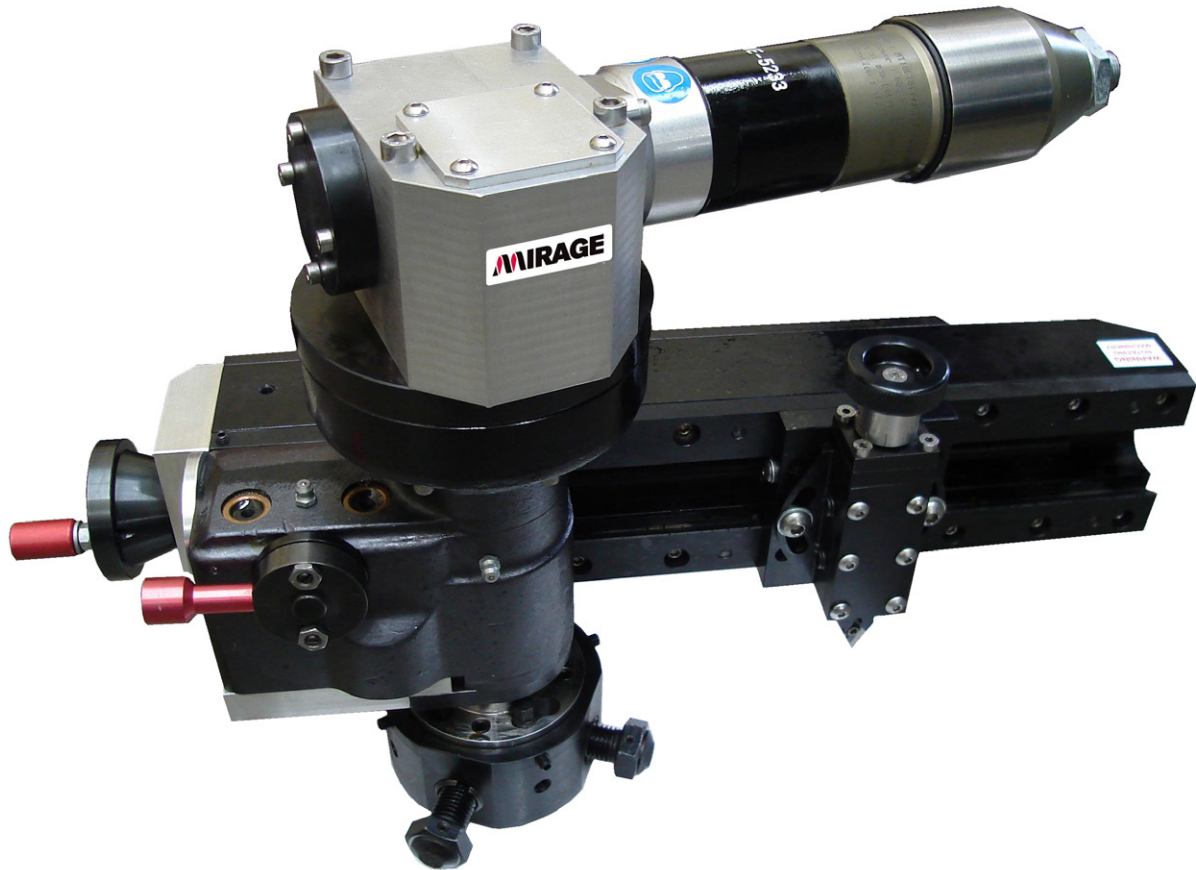

- Helical drive for superior surface finish
- Geared continuous groove facing feeds
- Swivel tool post
- Quick set independent base

An internally mounted lightweight yet strong flange facing machine for all types of flange facing, seal groove machining, weld prep and counter boring.

The machine is supplied complete with toolkit including tools and inserts, air filter lubricator and hose connection, all required mounting bases and extensions, storage / shipping box, CE certificate, packing list and manual.



All dimensions are for reference and may be subject to change without notice. Machine performance is subject to application and operator capability; please discuss your requirements directly with a Mirage sales representative. All information given and all sales made by Mirage Machines are subject to their terms and conditions, which are available at www.miragemachines.com.

Technical Details

Minimum Facing Diameter	50mm	2"
Maximum Facing Diameter	610mm	24"
Minimum Clamping Diameter	50mm	2"
Maximum Clamping Diameter	508mm	20"
Tool Post Travel	50mm	2"
R.P.M	Min: 20	Max: 42
Drive - Pneumatic @ 90 p.s.i (6 bar)	0.8 Kw	1.1 Hp
Air Consumption / Supply Required	1.2 m3/m	42 s.c.f.m

Feed Rates

Facing Feeds (1.75mm pitch feed screw)	0.12 / 0.48mm	0.006 / 0.019"
Facing Feeds (1.25mm pitch feed screw)	0.08 / 0.32mm	0.003 / 0.013"
Facing Feeds (1.0mm pitch feed screw)	0.06 / 0.24mm	0.002 / 0.010"

Weights and Dimensions

Machine Weight (independent base)	45 Kgs	99 Lbs	
Shipping Weight	62 Kgs	136 Lbs	
Shipping Dimensions	L - 67cm - (26")	W - 45cm - (18")	H - 38cm - (15")

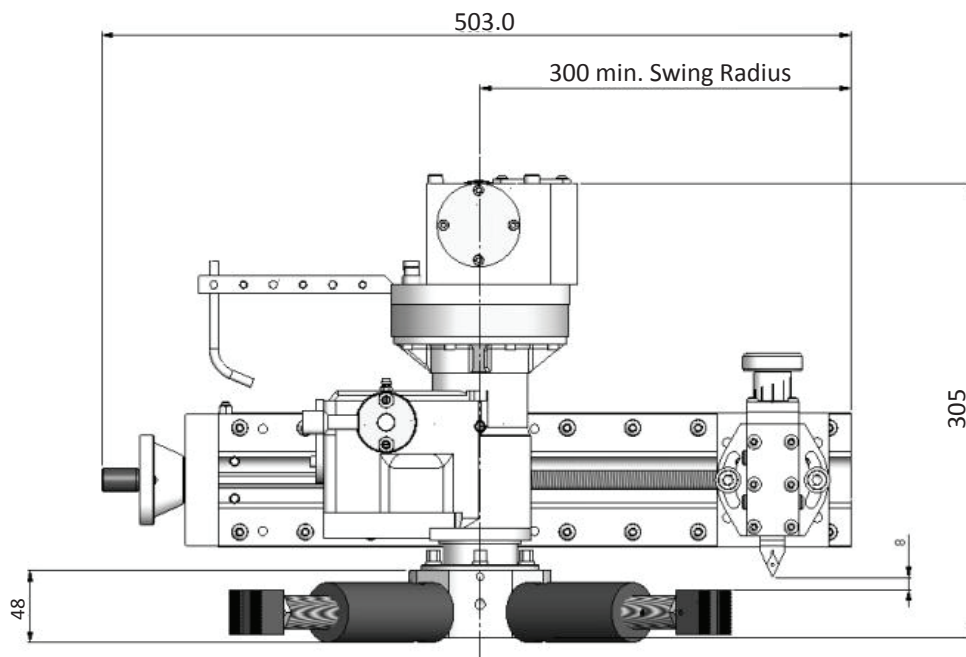

All dimensions are for reference and may be subject to change without notice. Machine performance is subject to application and operator capability; please discuss your requirements directly with a Mirage sales representative. All information given and all sales made by Mirage Machines are subject to their terms and conditions, which are available at www.miragemachines.com.