

45 - 120" (1150 - 3050mm)

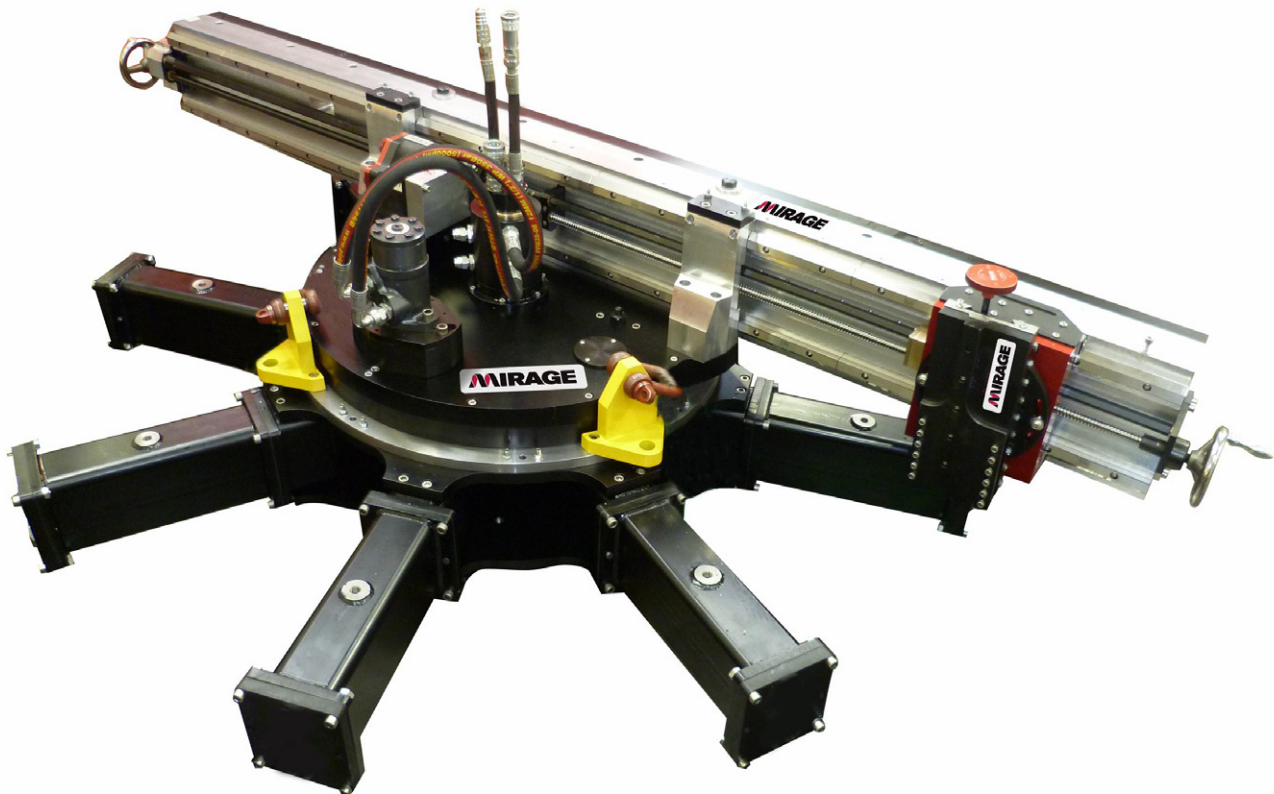

- Latest linear technology incorporated
- Powered tool post through 360 degrees
- 3 continuous groove feed gearbox
- High torque reduction drive
- Quick set adjustable clamping jaws

An internally mounted flange facing machine for all types of flange facing, seal groove machining, weld preparation, counter boring and heat exchanger repair. Optional orbital milling kit available.

The machine is supplied complete with toolkit including tools and inserts, air filter lubricator and hose connection, all required mounting bases and extensions, storage / shipping box, CE certificate, packing list and manual.



All dimensions are for reference and may be subject to change without notice. Machine performance is subject to application and operator capability; please discuss your requirements directly with a Mirage sales representative. All information given and all sales made by Mirage Machines are subject to their terms and conditions, which are available at [www.miragemachines.com](http://www.miragemachines.com).

### Technical Details

Minimum Facing Diameter	1150mm	45"
Maximum Facing Diameter	3050mm	120"
Minimum Clamping Diameter	1120mm	44"
Maximum Clamping Diameter	2800mm	110"
Minimum Swing Diameter	2615mm	103"
Tool Post Travel	102mm	4"
R.P.M	Min: 3	Max: 12
Drive - Hydraulic	5.0 Hp	3.73 Kw
Drive - Pneumatic @ 90 p.s.i (6 bar)	4.0 Hp	3.0 Kw
Hydraulic Requirements @ 70 bar	10 gal/min	50 Lpm
Air Consumption / Supply Required	2.69 m3/m	98 s.c.f.m

### Feed Rates

Facing Feed Rates (3 off In/Out)	0.20 - 0.32 - 0.81mm	0.008 - 0.012 - 0.032"
Boring Feed Rates (3 off Up/Down)	0.05 - 0.10 - 0.20mm	0.002 - 0.004 - 0.008"

### Weights and Dimensions

Machine Weight with Base - Max	1375 Kgs	3025 Lbs
Shipping Weight (Machine) - Box 1	1050 Kgs	2310 Lbs
Shipping Weight (Base) - Box 2	825 Kgs	1815 Lbs

Shipping Dimensions	Box 1	L - 285cm - (112")	W - 100cm - (40")	H - 75cm - (30")
	Box 2	L - 200cm - (78")	W - 115cm - (45")	H - 60cm - (24")

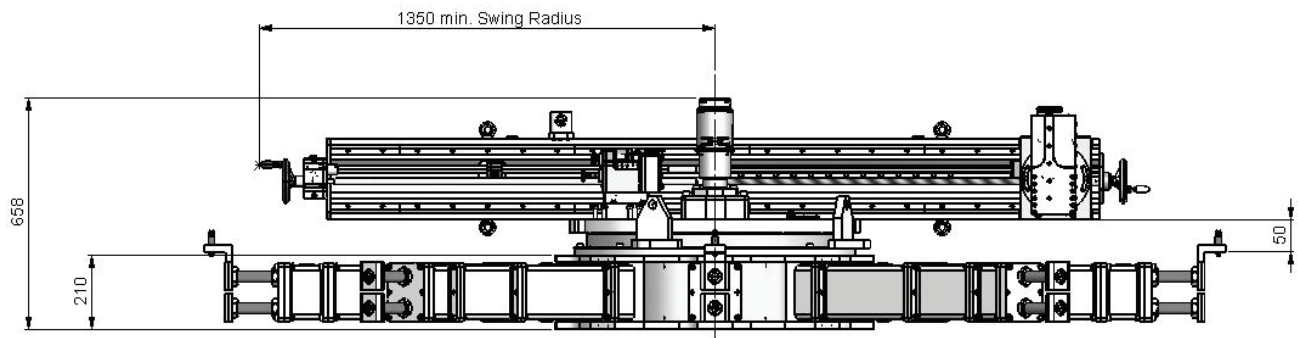

All dimensions are for reference and may be subject to change without notice. Machine performance is subject to application and operator capability; please discuss your requirements directly with a Mirage sales representative. All information given and all sales made by Mirage Machines are subject to their terms and conditions, which are available at [www.miragemachines.com](http://www.miragemachines.com).