

MiniMill – keyway Milling machine **2 - 20" (50 - 500mm) diameters**

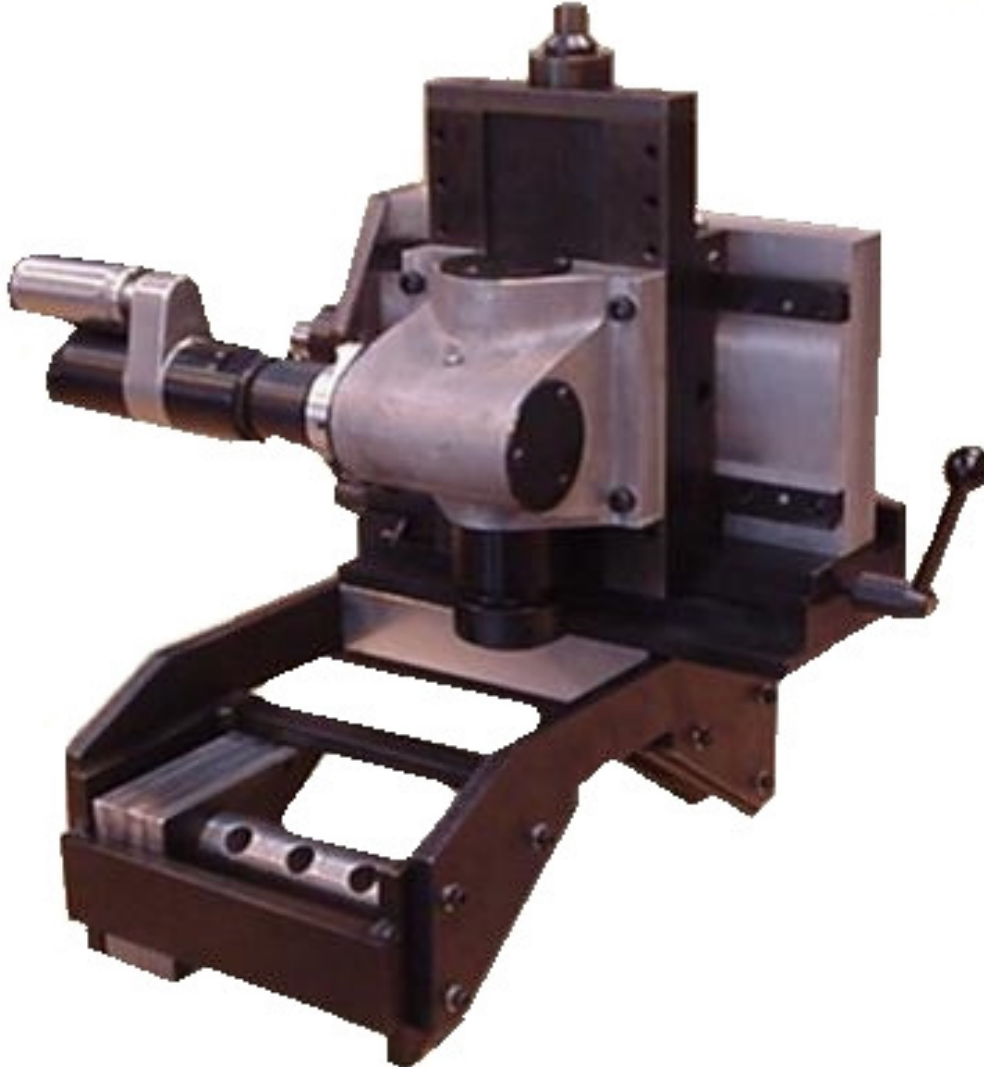

A lightweight portable 3 axis milling machine for the repair of keyways on shafts with 2 – 20" diameters

- ***Induction hardened 'V' slides***
- ***Quill type spindle – direct drive***
- ***Quick mounting chain system***
- ***Optional auto feed available***

Technical Details

RANGE		
Maximum stroke X	203mm	8"
Maximum stroke Y	50mm	2"
Maximum spindle down feed	50mm	2"
Drive - pneumatic	2.0 Hp	1.49 Kw
Drive - hydraulic	2.2 Hp	1.64 Kw
Spindle R.P.M	Min: 50	Max: 640
Hydraulic supply @ 1050 psi (70 bar)	50 L/min	13 gal/min
Air Consumption / supply required	98 s.c.f.m	2.69 m3/m

FEED RATES		
Hand feed	2mm /rev	0.078"/rev

WEIGHTS AND DIMENSIONS		
Machine weight (base additional 15kg)	50 kgs	110 lbs
Shipping weight	85 Kgs	187 lbs

Shipping dimensions	L - 58cm - (23")	W- 56cm (23")	H- 48cm (19")
---------------------	------------------	---------------	---------------

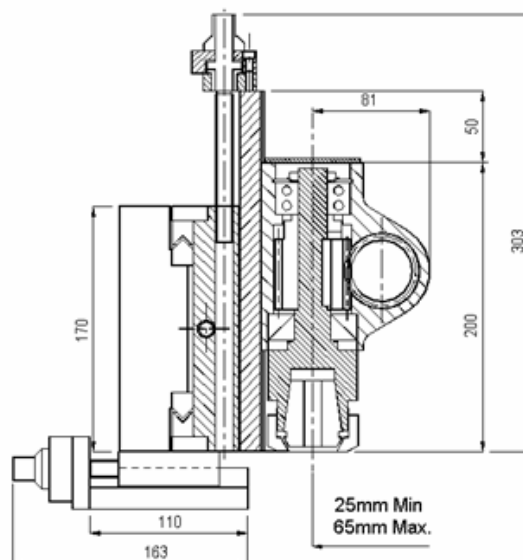

The machine is supplied complete with toolkit including air filter lubricator (when required) and hose connection, all required mounting bolts, storage / shipping box, CE certificate, Packing list and Manual

Pishgam Sanat Abzar Co.

Main office: No 372, 3rd floor, Abzar & Yaragh center, Imam Khomeini Street, Tehran, Iran
Tel. +982166712530, +982166713540

Manufacturing site: No. 3, 15 th St., Rezvanieh, Kamalshahr, Karaj, Iran. Tel.; +982634717900-4
info@pishgam.co.ir, www.pishgam.co.ir

