

HT60VF Portable Drill

17" stroke – Ø6" capacity



An versatile portable drilling and boring machine for heavy duty drilling and stud removal applications. The machine can be bolted directly to the work piece or have our new optional switch magnet base.

- 4 leg heavy duty construction**
- 5MT centre fed spindle**
- Variable auto feed gearbox and motor**

Technical Details

RANGE		
Maximum Hole diameter (through base)	152mm	6"
Standard stroke	450mm	17"
Maximum stroke available (optional)	610mm	24"
R.P.M – standard	Min: 5	Max: 60
Drive – Pneumatic @ 6 bar (90 p.s.i)	4.0 Hp	3.0 Kw
Drive – Hydraulic @ 70 bar (1050 p.s.i)	5.0 Hp	3.7 Kw
Feed – Pneumatic @ 6 bar (90 p.s.i)	1.5 Hp	1.11 Kw
Feed – hydraulic @ 70 bar (1050 p.s.i)	2.2 Hp	1.64 Kw
Air consumption required	98 s.c.f.m	2.69 m3/m
Hydraulic supply required	50 L/min	13 gal/min

FEED RATES		
Hand feed (Feed / revolution)	2.5mm	0.100"
Variable auto feed (optional)	0 – 32 mm/min	0 – 1.25"/min

WEIGHTS AND DIMENSIONS		
Machine weight (including 10kg auto feed)	87 kgs	191 lbs
Shipping weight	123 Kgs	270 lbs

Shipping dimensions	L - 115cm - (45")	W- 42cm (16")	H- 50cm (20")
---------------------	-------------------	---------------	---------------

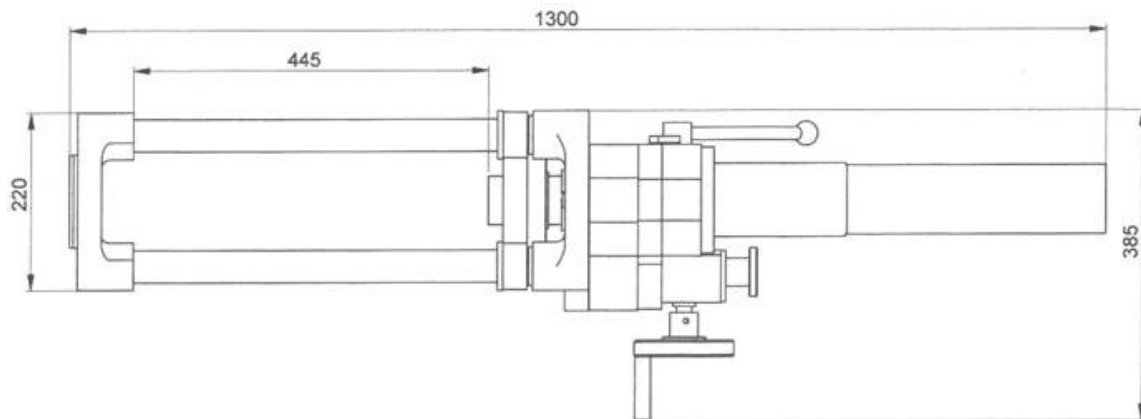

The machine is supplied complete with toolkit, air filter lubricator (when air driven) and hose connection, storage / shipping box, CE certificate, Packing list and Manual

Pishgam Sanat Abzar Co.

Main office: No 372, 3rd floor, Abzar & Yaragh center, Imam Khomeini Street, Tehran, Iran

Tel. +982166712530, +982166713540

Manufacturing site: No. 3, 15 th St., Rezvanieh, Kamalshahr, Karaj, Iran. Tel.: +982634717900-4

info@pishgam.co.ir, www.pishgam.co.ir

