

## **HT20 Portable drill**

**12" stroke – Ø2" capacity**



A versatile portable drilling and boring machine for general drilling and stud removal applications. The machine can be bolted directly to the work piece or have our new optional switch magnet base.

- ***Linear rails & guides – accuracy and rigidity***
- ***4MT spindle accepts standard tooling***
- ***Direct spindle drive***
- ***Auto feed / Hand feed gearbox and motor***

# HT20 Technical Details

RANGE		
Maximum Hole diameter (through base)	50mm	2"
Standard stroke	305mm	12"
Maximum stroke available (optional)	500mm	20"
R.P.M standard	Min: 15	Max: 100
Drive – Pneumatic @ 6 bar (90 p.s.i)	4.0 Hp	3.0 Kw
Drive – Hydraulic @ 70 bar (1050 p.s.i)	5.0 Hp	3.7 Kw
Feed – Pneumatic @ 6 bar (90 p.s.i)	1.5 Hp	1.11 Kw
Feed – hydraulic @ 70 bar (1050 p.s.i)	2.2 Hp	1.64 Kw
Air consumption required	98 s.c.f.m	2.69 m3/m
Hydraulic supply required	50 L/min	13 gal/min

FEED RATES		
Hand feed (Feed / revolution)	2.5mm	0.100"
Variable auto feed (optional)	0 – 32 mm/min	0 – 1.25"/min

WEIGHTS AND DIMENSIONS			
Machine weight (including 10kg auto feed)	43 kgs	95 lbs	
Shipping weight	60 Kgs	132 lbs	
Shipping dimensions	L - 76cm - (30")	W- 28cm (11")	H- 28cm (11")

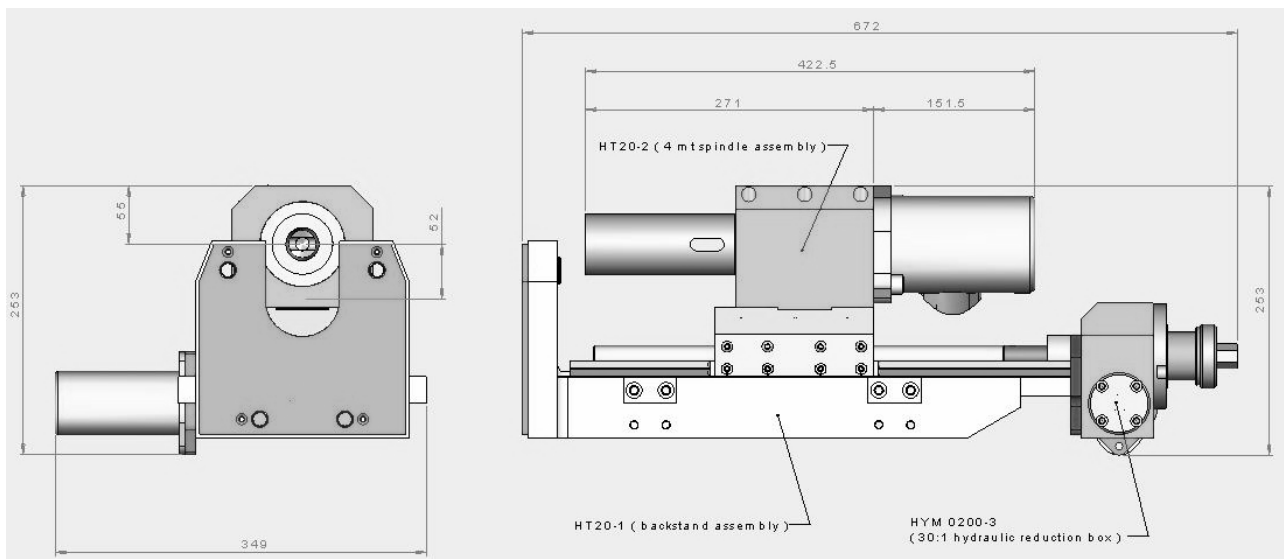

The machine is supplied complete with toolkit, air filter lubricator ( when air driven) and hose connection, storage / shipping box, CE certificate, Packing list and Manual

## Pishgam Sanat Abzar Co.

Main office: No 372, 3rd floor, Abzar & Yaragh center, Imam Khomeini Street, Tehran, Iran  
Tel. +982166712530, +982166713540

Manufacturing site: No. 3, 15 th St., Rezvanieh, Kamalshahr, Karaj, Iran. Tel.; +982634717900-4  
info@pishgam.co.ir, www.pishgam.co.ir

