

DDU1636 Casing Pin Drill **Ø6" – 36" diameters (multi string)**



A casing drilling unit for all lift pinning operations. Used in conjunction with the band saw to provide a very efficient method of cutting and decommissioning pipeline, conductors, caissons and multiple grouted strings.

- ***Linear precision guides for rigidity***
- ***Helical drive spindle for 4" , 6" ,10" , 12" pins***
- ***Steady nose bearing – consistent cuts***
- ***Swing gate quick clamp***
- ***Sub sea options available***



Technical Details

RANGE		
Minimum pipe diameter	152mm	6"
Maximum pipe diameter	915mm	36"
Minimum Clamping diameter	405mm	16"
Maximum Clamping diameter	915mm	36"
Min. / Max. Pin diameters (4" standard)	100mm / 4"	305mm / 12"
Cutting stroke	400mm	16"
R.P.M	Min: 10	Max: 60
Drive – hydraulic @ 1050 p.s.i (7 bar)	5.0 Hp	3.73 Kw
Hydraulic supply required (max. power)	50 L/min	10 gal/min

FEED RATES		
Advance manual Feed rate / revolution	4mm	0.157"

WEIGHTS AND DIMENSIONS		
Machine weight	472 kg	1038 lbs
Shipping weight	572 Kg	1258 lbs

Shipping dimensions 2 off boxes	L - 148cm - (58")	W- 173cm (68")	H- 79cm (31")
---------------------------------	-------------------	----------------	---------------

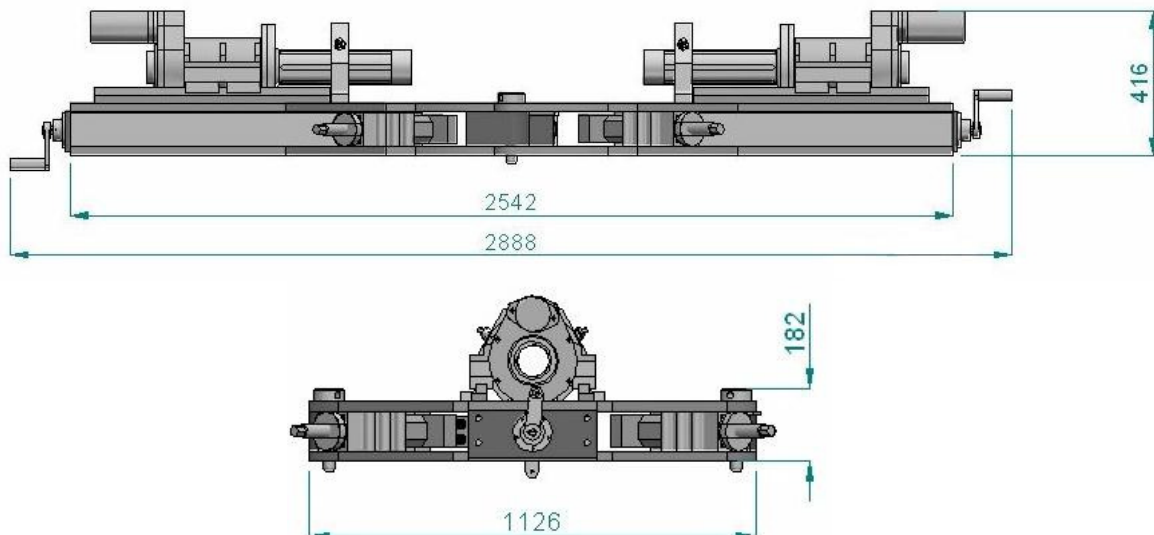

The machine is supplied complete with toolkit including quick release connectors, all required mounting legs and extensions, storage / shipping crate, CE certificate, Packing list and Manual

Pishgam Sanat Abzar Co.

Main office: No 372, 3rd floor, Abzar & Yaragh center, Imam Khomeini Street, Tehran, Iran
Tel. +982166712530, +982166713540

Manufacturing site: No. 3, 15 th St., Rezvanieh, Kamalshahr, Karaj, Iran. Tel.; +982634717900-4
info@pishgam.co.ir, www.pishgam.co.ir

